

REV.	REVISED DESCRIPTION	DATE	CHECKED
A0	FIRST RELEASE	2017/12/11	

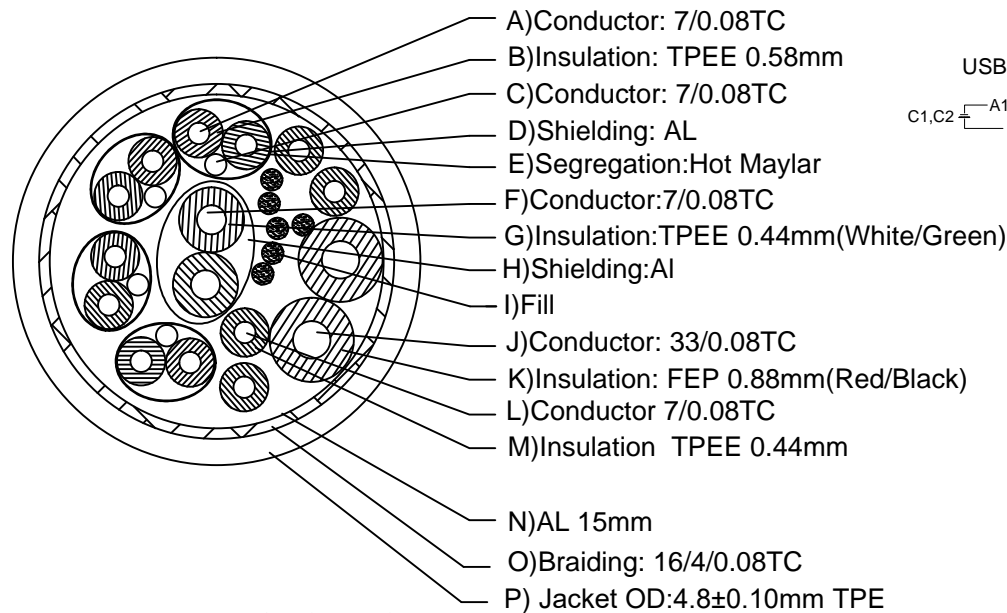

3.1 USB Cable Spec.

CONNECTION

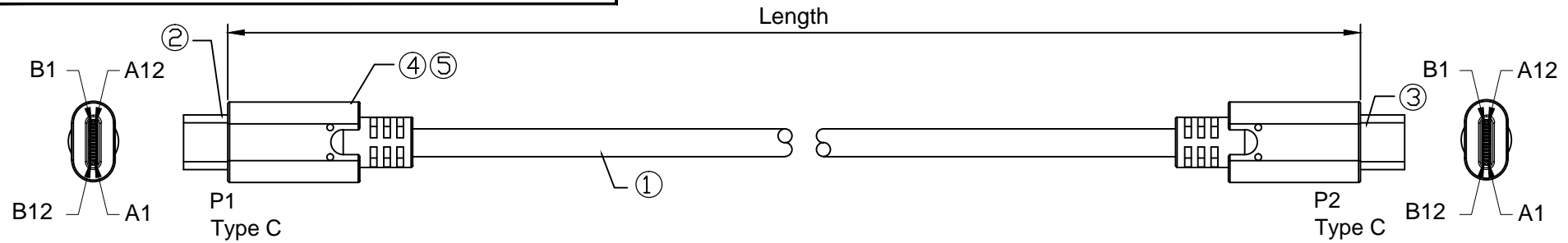
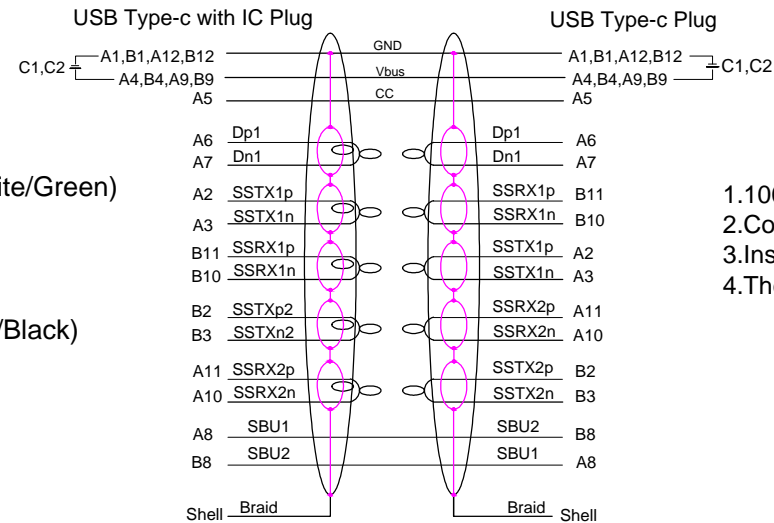

Remark:

- 100% Open/Short Test
- Conductive Resistance: 20ohms MAX
- Insulation Resistance: 5M ohm MIN.
- The product is Reach/RoHS compliant.

Item No.	Length(m)
AC7345	1.0m

ITEM	DESCRIPTIONS & SPECIFICATIONS	QTY	REMARK
④	External Mold	Outer Mould 45P PVC, Black	2PCS
③	Inernal Mold	Inner Mould PE	2PCS
②	Connector	USB Type C, PCBA(W/Capacitor, Resistor)	2PCS
①	Cable	$[(7/0.08TC+0.58TPEE)*1P+D(7/0.08)+AL+Mylar]*4P+$ $[7/0.08TC+0.44TPEE(Whiter/Green)]*1P+$ $[33/0.08TC+0.88FEP(Red/Black)]*2C$ $+[(7/0.08TC+0.44TPEE)]*4P+Silk\ wire+AL$ $+16/4/0.08TC+TPE\ OD4.8mm$	

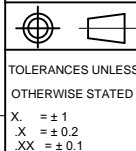

ERP NO.:		SAMPLE DWG NO:	
DOC No.:		REVISION	A0
CUSTOMER:		UNIT	mm
CUSTOMER P/N:		SCALE	NO
DESCRIPTION	USB 3.1 Type C male to Type C male	PAGE NO	1/1
		DATE	2017/12/11
APPROVAL		CHECKED	
		DRAWN	